

# Audio and Speaker Connections (continued)

## Internal Amplifier Volume Controls

Use the MP3 volume controls for audio coming from the FlexMax. Use the MIX volume controls to control an external audio source you'd like to mix in.

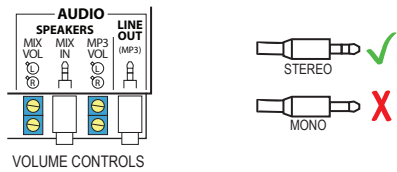

## Connecting Amplified Speakers

The FlexMax audio output is designed to connect to powered speakers or external amplifiers.

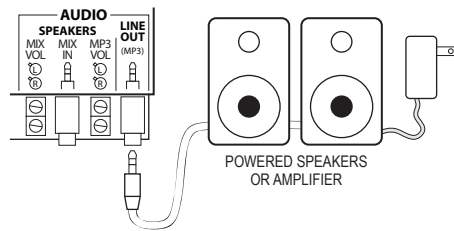

## Copying Audio Files to the BooBox

The recommended method to get your audio files onto the BooBox is to use our free Director software. It will copy the sounds to your BooBox or ScareMaster and ensure the filenames and folder structure are correct. If you are using a Mac, or prefer to copy the files on your own, see the full manual for SD card layout details.

# Programming

BooBoxes can be easily programmed with our free Director software and an SD card. The Director Connect allows you to see your work in real-time, rather than having to save the program to an SD card first. The ScareMaster is a great real-time programming option for those who don't want to be tethered to a computer.

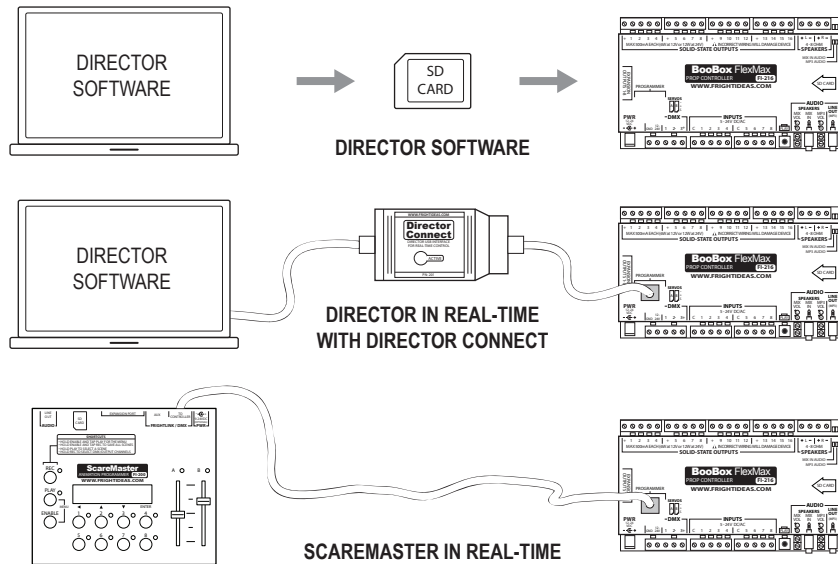

# Tips and Tricks

The BooBoxes have some great features that are often left undiscovered. The full list can be found in the manual available online. Below are just a few examples:

- Ambient Resume* - Tells the Ambient scene to resume from where it left off after an input scene has finished.
- Play All Sound Mode* - Fill a scene folder with audio files and the BooBox will play them all. Great in Ambient mode!
- Fade on Interrupt* - If a scene is interrupted before completion it will fade out the audio before stopping.
- Manual Playback* - Hold the PLAY button for a few seconds to select which Input scene you'd like to trigger.



## Quick-Start Guide BooBox FlexMax

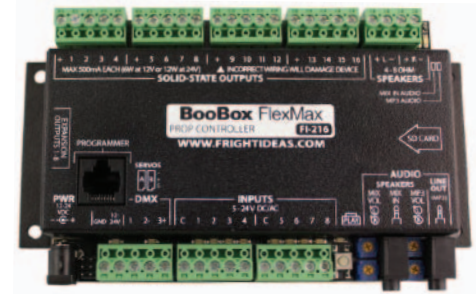

### MORE INFORMATION ONLINE

This guide covers only a fraction of what the FlexMax can do. Tutorial videos and a full manual are available online.

# Power Supply

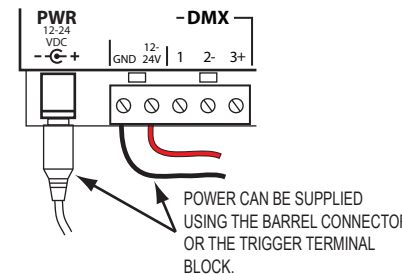

## Sizing Your Power Supply

To size a supply you must add up the wattage for the most outputs that will be on at any one time, then add 2 watts for the FlexMax if you're NOT using the internal amplifier, or 50 if you are.

Example:

- 50 watts FlexMax using Amp (24 volts is best)
- + 36 watts 6 x 6 watt solenoids
- = 86 watts Need a 24 VDC > 86 watt supply

## About Solid-State Outputs

Solid-state outputs are great for reliably controlling relays, solenoids, and LED lights. They cannot be used to directly control high-current, AC powered, or contact-closure devices like a relay can. However, unlike relays, they have no moving parts that will wear out over time. Use external relays for these loads. Keeping these moving parts outside of the controller allows them to be easily replaced when they wear out.

# DMX

## Master Mode (Default)

The FlexMax can be linked to our BooTunes or BooTunes Amped MP3 players to add more audio channels. It can also be connected to other BooBoxes or DMX fixtures to control them in sync with the rest of the show.

## Slave Mode

The FlexMax can be setup as a DMX slave to another FlexMax or DMX controller. The controller can then control the Flex's outputs and audio, or trigger scenes depending on the DMX mode.

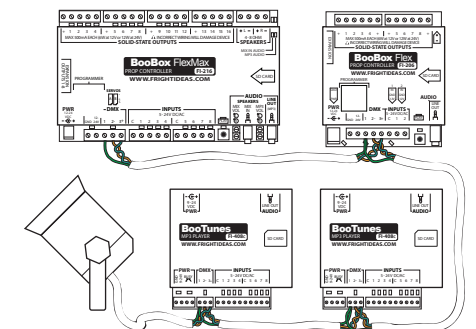

# Solid-State Output Wiring Diagrams

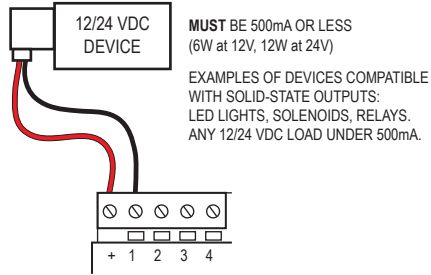

ANY 12 OR 24 VDC DEVICE

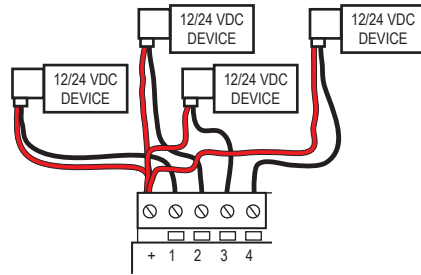

FOUR 12 OR 24 VDC DEVICES

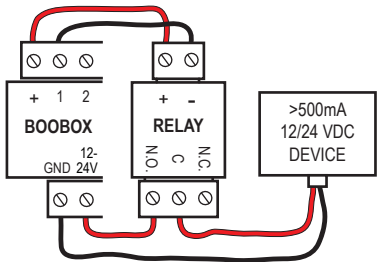

12 OR 24 VDC DEVICE > 500mA

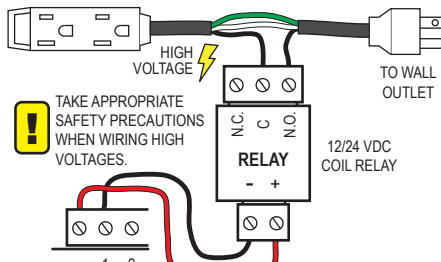

ANY 110 VOLT LOAD

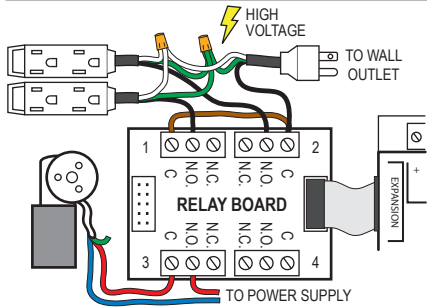

USING A BOOBOX RELAY BOARD

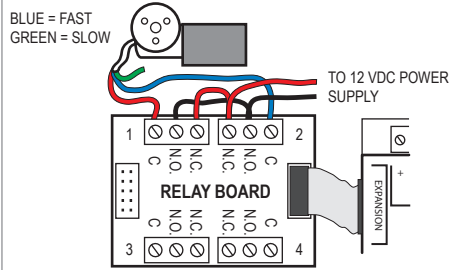

12 VDC MOTOR IN FORWARD AND REVERSE

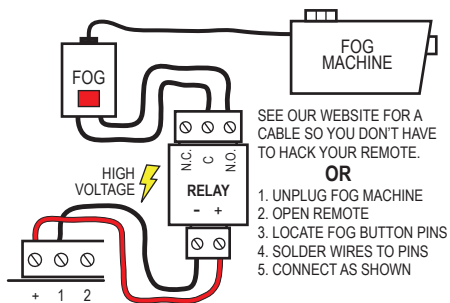

FOG MACHINE

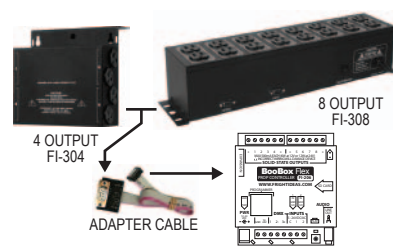

USE ONE OF OUR AC RELAY PACKS WHEN YOU HAVE A LOT OF 110 VOLT DEVICES TO CONTROL.

AC RELAY PACKS

# Trigger Input Wiring

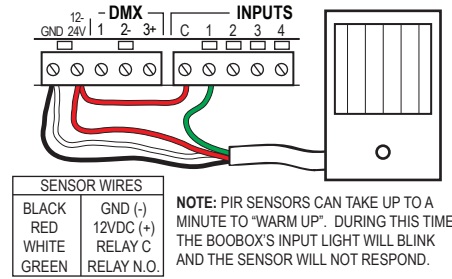

PIR MOTION SENSOR

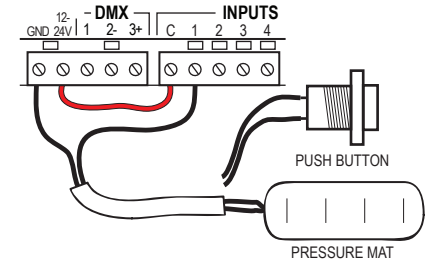

PRESSURE MAT OR PUSH BUTTON

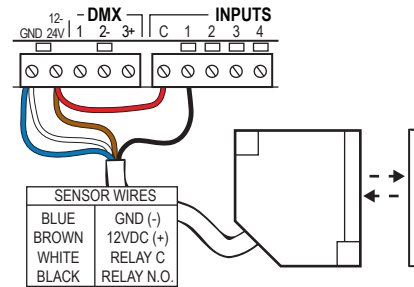

BEAM SENSOR

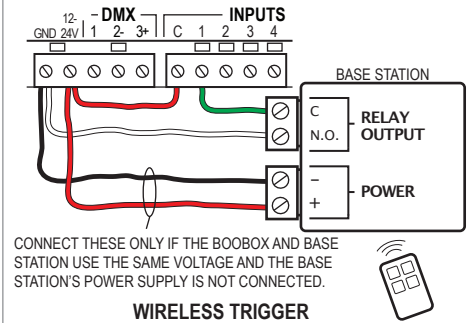

WIRELESS TRIGGER

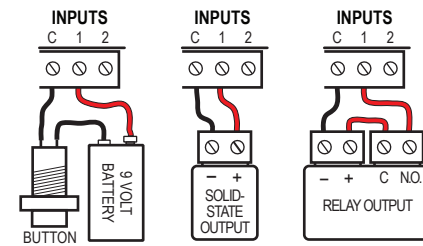

OPTICALLY-ISOLATE CIRCUITS FROM DIFFERENT POWER SUPPLIES, OR WHEN WIRE LENGTHS ARE EXCESSIVE.

OPTICALLY-ISOLATED INPUT

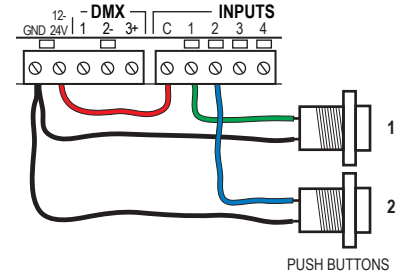

TWO TRIGGERS

# Audio and Speaker Connections

The FlexMax includes a 50 watt (2 x 25 watt) Class D stereo amplifier. To take full advantage of this amplifier, the power supply needs to be 24 volts and have at least 50 watts of power.

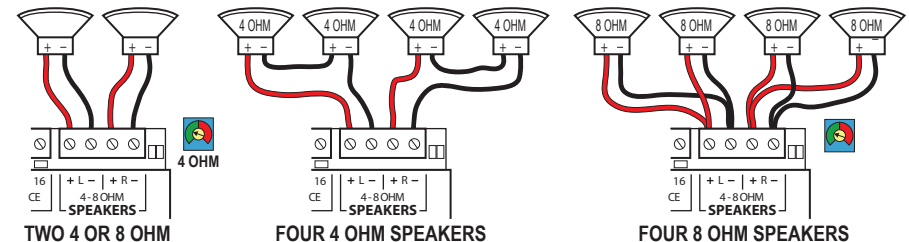

TWO 4 OR 8 OHM

FOUR 4 OHM SPEAKERS

FOUR 8 OHM SPEAKERS

= DO NOT turn the volume past 50% if using a 24 volt power supply in this configuration.